

Orchestra Show Rider



On behalf of the cast and crew of Five By Design's *Stay Tuned*, we wish to thank you for contracting the company as part of your upcoming season. To ensure that the performance runs efficiently, we require your Production/Technical Manager to thoroughly read the enclosed contractual and technical information and sign below. This rider is an integral part of the contract. Please be sure to retain the original document for your records and fax or mail a signed copy to us at:

Five By Design
1160 Vierling Drive, #353
Shakopee, MN 55379-4313
Fax # (952) 400-4229

We understand each venue may have certain limitations. Please feel free to contact us to discuss alternatives or substitutions if you should have any questions regarding the materials contained in the rider. We can be reached through our offices at (800) 449-7345.

Warmest regards,

Five By Design

(Production/Technical Manager)

(Telephone Number)

(Date)

Five By Design personnel:

| | | |
|-----------------------------|---|----------------|
| Kurt Niska | Artistic Director/C.E.O..... | (612) 802-8171 |
| Michael Swedberg | Executive Director..... | (612) 991-2308 |
| Midge Swedberg | Office Manager | (800) 449-7345 |
| Sheridan Zuther..... | Operations Manager | (612) 799-0245 |
| Laurel Stinson..... | Technical Director..... | (612) 991-2193 |
| Phil Henrickson..... | Sound Engineer | (920) 755-2328 |
| Terrence Niska | Music Librarian & Marketing Director..... | (952) 496-2358 |
| Lorie Carpenter-Niska | Tour Coordinator..... | (952) 496-2358 |

Artist Representation:

| | | |
|----------------------|--------------------------------------|----------------|
| Alton Accola..... | <i>Symphony Pops</i> | (800) 449-7345 |
| Catherine Scott..... | <i>Performing Arts Centers</i> | (612) 991-3528 |
| Steve Pritchard..... | <i>Music City Artists</i> | (615) 383-4862 |

Stay Tuned Orchestra Rider

These items are necessary to a successful production. Your assistance in providing this information and materials will greatly assist Five By Design to present the best possible performance.

Please review the enclosed pages and call us at (800) 449-7345 if you have questions or concerns.

Five By Design personnel:

| | | |
|-----------------------------|---|----------------|
| Kurt Niska | Artistic Director/C.E.O..... | (612) 802-8171 |
| Michael Swedberg | Executive Director | (612) 991-2308 |
| Midge Swedberg | Office Manager | (800) 449-7345 |
| Sheridan Zuther..... | Operations Manager | (612) 799-0245 |
| Laurel Stinson..... | Technical Director..... | (612) 991-2193 |
| Phil Henrickson..... | Sound Engineer | (920) 755-2328 |
| Terrence Niska | Music Librarian & Marketing Director..... | (952) 496-2358 |
| Lorie Carpenter-Niska | Tour Coordinator..... | (952) 496-2358 |

IN ADVANCE:

- 1) Professional lighting and sound system to meet specifications of the enclosed "Lighting" and "Sound" requirements. Experienced technicians should be available to assist with Load-In, Load-Out, and to answer any questions. Please read the attached "Lighting" and "Sound" pages for specific information.
- 2) Business and/or home phone numbers of presenter, venue's technical director and staff.
- 3) A map detailing the location of hotel, performing arts venue, appropriate routing, and phone numbers. Please be specific as to the location of loading dock and the stage door of your venue when providing directions.
- 4) A schematic of the performance venue stage (including an inventory of lighting and sound equipment).
- 5) Hotel or Motel (Residence Inn, Courtyard, Comfort Suites, or comparable) near venue with swimming pool, sauna, whirlpool, exercise facility and internet access. **NON-SMOKING ROOMS** are required, all at the same complex.
- 6) Allow broadcast and print media the opportunity to photograph and/or videotape segments of the rehearsal or performance with the orchestra. (No flash photography during performance.)
- 7) Regarding social functions or outreach activities, please inform company a minimum of 30 days in advance.
- 8) Regarding orchestral arrangements and scores, please provide name and address of who is to receive the music. Please provide rehearsal availability and schedule as soon as possible to our Operations Manager.
- 9) Piano, Acoustic Bass (with Pickup and Amplifier), and Drum Kit are to be provided by presenter. Please see the "instrumentation list" and "contract" included for specific information of what will be needed for your venue.
- 10) To provide a proper balance between the vocalists and the orchestra and because lighting is an integral part of the performance, we ask that an **acoustical shell not be used** for the *Stay Tuned* production.
- 11) Production specific marketing and promotional materials are available for the presenter at company's website: <http://www.fivebydesign.com/StayTuned.html>. Prior to going to print, contact our Operations Manager for program information, content and layout approval (i.e. personnel and program changes). If additional needs or questions arise, please contact our Marketing Director for assistance.
- 12) Contact Five By Design's Operations Manager to arrange a hot meal for ten (10) prior to the show.

Stay Tuned Orchestra Rider

PRIOR TO LOAD-IN:

- 1) Piano must be tuned prior to (but within 24 hours of) Load-In, following Rehearsal prior to performance, and before each subsequent performance. If venue has a second (rehearsal) piano, please make it accessible for warm up prior to show and during intermission.
- 2) The Stage Set-Up must be complete prior to Load-In. Lighting instruments should also be pre-hung and gelled before Load-In. See attached "Set-Up Diagram" and "Lighting" for specific requirements

AT LOAD-IN:

- 1) Performance venue must be available for Load-In a minimum of eight (8) hours prior to rehearsal with the orchestra. (In the event of an AM rehearsal, venue must be available for Load-In the afternoon prior.) Performance venue must also be available Two (2) hours prior to each performance.
 - Load-In and prep for show typically takes six (6) to seven (7) hours [not including meal breaks].
 - Load-Out typically takes two (2) to two and a half (2 1/2) hours.
- 2) Six (6) Stagehands for Load-In and Load-Out, and to assist with other incidental needs:
 - Load-In and Load-Out Crew Requirements: 1 Sound, 1 Light, 1 Wardrobe, 3 Hands.
 - Show Call Crew Requirements: 1 Sound, 1 Light, 1 Follow spot, 3 Stage Crew (2 stage left, 1 stage right).
- 3) The following are required no later than Load-In time:
 - Two (2) sturdy movable clothing racks (preferably high enough to accommodate floor length gowns).
 - Two (2) eight foot table (1 stage left and 1 stage right).
 - Music stands for orchestra plus eight (8) extra for actors (4 offstage left, 4 offstage right).
 - Music stand lights for orchestra plus six (6) extra for actors (4 offstage left, 2 offstage right). Onstage lights will be on a dimmer. Company will provide a light for the piano that should be included in the circuit allocated to the stand lights. See attached "Lighting" rider.
 - 16 total chairs (7 chairs offstage right, 8 chairs offstage left, 1 chair for Typewriter).
 - One (1) adjustable piano bench.
 - Pipe and drape may be needed to create two (2) Quick change areas: one located Stage Left 16' x 20', and one Stage Right 16' x 12'. These locations will be determined during Load-In.
 - Three (3) gallons of **distilled** water for our clothing steamers. (**Not** drinking, spring or tap water).
 - Access to stage from house, i.e. steps (on at least the stage right side for rehearsals and performances).
 - Hot herbal tea (non caffeinated with honey and lemon) regular coffee, non carbonated bottled water (i.e. Evian), Coca-Cola and cups. Please have bottled water, herbal tea and coffee available at rehearsal(s) and performance(s) as well.
 - A fruit and veggie tray available for cast and crew following each performance(s).
 - Five (5) clean Dressing Rooms to accommodate 2 people each, through run of show.
 - Company travels with a 24' box truck (35' feet long, 13' high) and a 15 passenger van. Please arrange for level, secure parking. The truck is equipped with a battery cut-off switch.

***Stay Tuned* Orchestra Lighting Requirements**

Questions regarding lighting requirements contact:

Laurel Stinson, Technical Director..... cell: **(612) 991-2193**

e-mail: **laurel.stinson@fivebydesign.com**

- Please mail or fax a schematic of your performance venue stage and lighting grid (including a lighting inventory) to the company's Operations Manager.

Stay Tuned requires a safe and well maintained lighting system. The inventory must be adequate to complete the hanging of the enclosed plot prior to Load-In. Please have a safe lift or ladder available for focus. **If you anticipate the need to rent any equipment for your venue, please contact us prior to doing so, to make certain it is necessary. Substitutions may be suggested.**

Console

The lighting console must be either a computer memory console or a two scene preset board with a minimum of 48 channels (ETC or STRAND family is preferred).

Follow spot

We require one (1) follow spot adequate to the venue. A Xenon Super Trouper is preferred for medium to large venues. Spot Color is Rosco 02, 33, 54, 60, 119 or 132 in frames 1 through 5 respectively. LEE or GAM substitutions are acceptable.

Crew Requirements

We require one technician familiar with your lighting system to be present at Load-In and during the run of the show, and one follow spot operator for run of the show. Our Technical Director will operate the board for the run of the show. If this presents a problem, please contact our technical personnel at least thirty (30) days in advance of the performance. Six (6) Stagehands for Load-In and Load-Out, and to assist with other incidental needs:

- Load-In and Load-Out Crew Requirements: 1 Sound, 1 Light, 1 Wardrobe, 3 Hands.
- Show Call Crew Requirements: 1 Sound, 1 Light, 1 Follow spot, 3 Stage Crew.

Orchestra Requirements

The Orchestra Set-Up (see diagram attached) must be completed prior to the scheduled Load-In. The appropriate background for the production is a full-stage white **cyclorama** behind the orchestra. Since there is no acoustical shell being used that would normally provide overhead light for the orchestra, please hang top lights to do so. The Orchestra light should be a three color top wash (i.e. R68, R26 and R17). **Music stand lights are required for conductor and musicians; please place them on a dimmer patched into Channel 34.** We require a minimum of fifteen (15) feet down stage of the conductor's podium for performance space.

Gobo Requirements

Presenter will provide the gobos listed below to fit their current lighting inventory. Substitutions may be discussed prior to Load-In. PLEASE NOTE: Five by Design will provide some additional gobos for the light plot **not** mentioned below.

ROSCO PATTERNS:

- Two (2) - Pattern #77770 – Music (Channel 8 on light plot).
- One (1) - Pattern #77302 – Skyline 1 (Channel 35).
- One (1) - Pattern #77306 – Skyline 2 (Channel 35).
- One (1) - Pattern #79001 – Night Sky (Channel 40).
- Two (2) - Pattern #79111 – Jungle Vignette (Channel 38).
- One (1) - Pattern #77750 – Arcadia (Channel 41).

GAM PATTERNS:

- One (1) – Pattern #517 – Twisting Branches (Channel 23).
- One (1) – Pattern #635 – Construction A (Channel 24).
- One (1) – Pattern #636 – Construction B (Channel 24).

***Stay Tuned* Orchestra Lighting Requirements (cont.)**

Important Information regarding the Light Plot

- Trim heights in the plot are approximately 23 feet.
- All instruments should be at least 750 watts and should be consistent wattage for equal throw distances.
- If substitutions of either inventory or color are anticipated, please contact our technical/lighting director.
- The light plot is based on a sixty (60) foot proscenium. If your performance space is different, please expand or condense the spacing on the electrics as needed.
- Please refer to light plot attached for additional notes.
- Stand lights are to be placed on a dimmer. Please make sure the orchestra players are aware that there will be blackouts during the show.
- Five By Design travels with a number of additional gobo patterns for the light plot that are not included in the “Gobo Requirements” on page 4. The venue will need to provide Size “B” pattern holders. Donuts may be required for all instruments using gobo patterns in order to ensure crisp patterns and breakups for the production.

PLEASE NOTE: In order to ensure a quick and proper load-in of the show, we ask that all lights be gelled and hung prior to load-in. If this can not be accommodated, please contact the Technical Director immediately.

***Stay Tuned* Orchestra Sound Requirements**

Questions regarding sound requirements contact:

Phil Henrickson, Sound Engineer: **(920) 755-2328**fax: **(920) 755-4442**
e-mail: **philhenrickson@yahoo.com**

- Company travels with a system adequate for a 1000 seat auditorium with no balcony. Please advise as to size of venue and type of in-house system available as Company may need to patch in to the House PA for additional coverage. **If you anticipate the need to rent any equipment for your venue, please contact our Sound Engineer prior to doing so, to make certain it is necessary.**
- Sound Engineer will use his own console for the purpose of mixing the live performance. Please provide a five (5) foot by eight (8) foot house-mix position for company's sound gear. Rear of house on the main floor is preferred.
- If the cable path from the stage to the House Mix position is greater than one hundred and fifty (150) feet, please provide one (1) Snake, with 24 in - 5 out minimum.
- Three (3) separate twenty (20) amp circuits exclusively for sound gear. One located at House Mix position, and one located off stage right and one for the Bass Player's amplifier onstage (see Set-Up Diagram).
- Please provide a Plexiglas surround for the drum kit (three of four sides is fine).
- Six (6) microphone stands. (three (3) boom stands and three (3) straight stands)
- Company travels with Three (3) monitors for the rhythm section and One (1) for the brass section (see Set-Up Diagram). If you anticipate the need for additional monitors (i.e. the conductor, percussion, etc.) please be prepared to provide the necessary equipment.
- During the rehearsal(s) and show(s) the House Sound person is responsible for any balance issues of the Orchestra and should provide our sound man with a final mix to be balanced with the vocalists in the house P.A. The company's sound man is responsible for mixing the vocalists, the Rhythm Section mix, and overall balance between the vocalists and orchestra.
- **Any further amplification of the orchestra would be in addition to these requirements** and is at the discretion of the symphony and/or conductor. If you anticipate the need for additional amplification of the orchestra, please be prepared to provide sufficient equipment.

Crew Requirements

We require one technician familiar with your sound system to be present at Load-In, and during the run of the show. Six (6) Stagehands for Load-In and Load-Out, and to assist with other incidental needs:

- Load-In and Load-Out Crew Requirements: 1 Sound, 1 Light, 1 Wardrobe, 3 Hands.
- Show Call Crew Requirements: 1 Sound, 1 Light, 1 Follow spot, 3 Stage Crew.

Communication

We require two-way headset communication at the following locations:

- lighting console
- follow spot
- stage left
- stage right
- sound mix

PLEASE CALL 3 - 4 weeks prior to Load In to clarify, verify, and address any concerns.

***Stay Tuned* Orchestra Stage Requirements**

Questions regarding stage requirements contact:

Laurel Stinson, Technical Director: cell: **(612) 991-2193**

e-mail: laurel.stinson@fivebydesign.com

- The Orchestra Set-Up (see diagram) must be completed prior to the scheduled Load-In
- To provide a proper balance between the vocalists and the orchestra and because lighting is an integral part of the performance, we ask that the **acoustical shell not be used** for the *Stay Tuned* production. The appropriate background for the production is a full stage white **Cyclorama** behind the orchestra.
- Due to the nature of the scenery elements required for the show, **space on stage might be an issue**. We highly recommend that our instrumentation listing and set-up diagram be followed.
- We require a minimum of Fifteen (15) feet down stage of the conductor's podium for performance space. Please contact our Technical Director if this cannot be accommodated.
- We require two backstage wing space for quick changes: one offstage left (approximately 16' x 20') to accommodate two (2) clothes racks, one gondola, an 8'-0" table and eight (8) chairs and one area offstage right (approximately 16' x 12') to accommodate one gondola and seven (7) chairs.
- Theatre borders and legs will be used for masking. If this is not sufficient to properly mask quick change areas from audience view, pipe and drape may need to be provided. Quick change areas will be determined at Load-In.

Brief explanation of our Props:

- All scenery elements on the Set-Up Diagram are pieces that we bring with us (including two (2) rolling set pieces, two (2) doors, the table for the typewriter, the table for the props for the commercial medley and the five (5) Microphones downstage center).
- A few scenery elements will roll on from stage right and stage left (two freestanding doors, two rolling sled units). These elements are designed to roll through a standard door frame. If there is no way that these items can physically go on and offstage, they will have to live onstage.

Items that the Presenter needs to provide:

- Risers for the Orchestra (i.e. Wenger standard 4'-0" by 8'-0" and 4'-0" by 4'-0" risers at incremental heights of 8", 16" and 24".) **The back of both lower and upper levels must have a chair rail**. The Orchestra Set-Up (see diagram) must be completed prior to the scheduled Load-In.
- **Music stands and stand lights** are required for the musicians. (These stands are included in the count requested on page 3 in the "At Load-in" section.) **The stand lights will be placed on a dimmer, patched into Channel 34**. Refer to the Set-Up Diagram for additional requirements. (Five By Design will provide a light for the piano that should be included in the circuit allocated to the stand lights).
- One (1) Concert Grand Piano. Piano must be tuned prior to (but within 24 hours) of Load In, following Rehearsal prior to performance and before each subsequent performance.
- Two (2) 8 ft. table (1 offstage left and 1 offstage right).
- 8 music stands for actors (4 offstage right, 4 offstage left).
- 16 total chairs (7 chairs offstage right, 8 chairs offstage left, 1 chair for Typewriter).
- 1 adjustable piano bench.



1160 Vierling Drive, #353
Shakopee, MN 55379-4313
(952) 496-2358
e-mail: terrence.niska@fivebydesign.com
Terrence Niska, Librarian

Instrumentation List* for *Stay Tuned* with Orchestra

- ◇ Flute 1 & 2
- ◇ Piccolo (double Flute)
- ◇ Clarinet 1 & 2
- ◇ Oboe 1
- ◇ Bassoon 1
- ◇ Tenor Saxophone (double Alto Saxophone and Baritone Sax)
- ◇ French Horn 1, 2, 3, & 4 (mutes)
- ◇ Trumpet 1, 2, 3 & 4 (cup, harmon, straight and plunger mutes)
- ◇ Trombone 1, 2 & 3 (cup, harmon, straight and plunger mutes)
- ◇ Tuba
- ◇ Percussion 1 & 2
Xylophone, Bells (with hard & soft mallets), Vibes, Marimba, Suspended cymbal, Triangle, Small triangle, Maracas, Cabasa, Cowbell, Congas (high & low) or Bongos, Timbales, Castanets, Slap Stick, Slide Whistle, Cymbals, Claves
- ◇ Timpani (3) [*32", 29", 26" are recommended*]
- ◇ Drum Set, including:
Kick Drum, Snare Drum, Hi Tom, Medium Tom, Low (Floor) Tom, Hi-Hat, 2 Ride Cymbals, Crash Cymbal, Woodblock, Sticks, Brushes, Soft Mallets for Cymbals, Cowbell, Throne, Area Rug
- ◇ Electric Guitar (with amplifier)
- ◇ Grand Piano
- ◇ Violin 1 (10)
- ◇ Violin 2 (8)
- ◇ Viola (6)
- ◇ Cello (6)
- ◇ Contrabass (1 Jazz upright with pickup and amplifier)
3/4-7/8 Size Bass
Fully Carved instrument with bow (German, French, Italian)
Thomastik Spirocores strings
Pickup attached, preferably "The Realist"
Bass Amp Recommendations : Yamaha, Mesa Boogie

***This is only a list of the instruments required by our orchestrations. Check the Contractual Agreement prior to hiring players to insure accurate personnel requirements.**

STAY TUNED (ORCHESTRA) SET-UP DIAGRAM

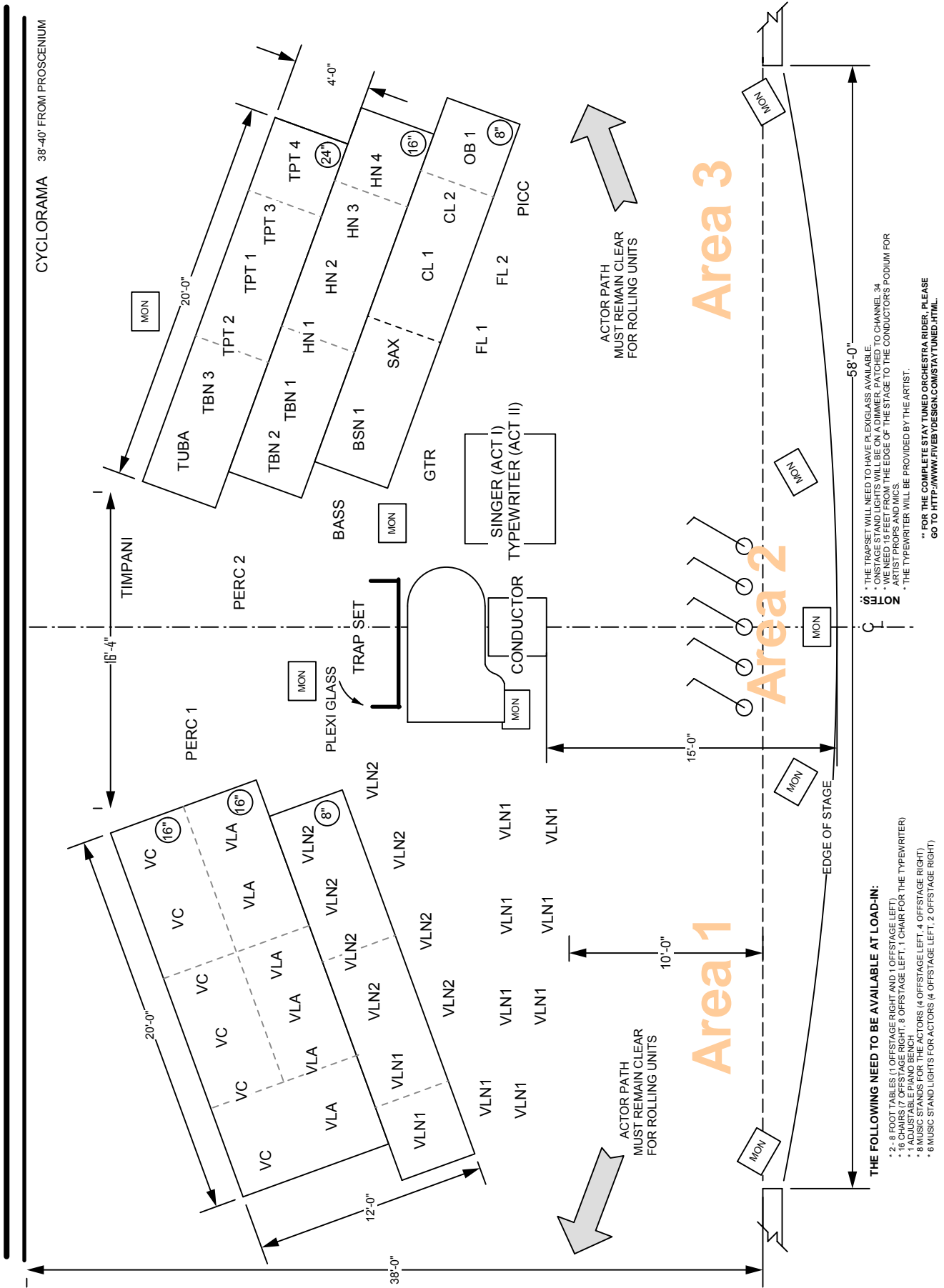

THE FOLLOWING NEED TO BE AVAILABLE AT LOAD-IN:

- * 2 - 8 FOOT TABLES (1 OFFSTAGE RIGHT AND 1 OFFSTAGE LEFT)
- * 16 CHAIRS (10 OFFSTAGE RIGHT, 8 OFFSTAGE LEFT, 1 CHAIR FOR THE TYPEWRITER)
- * 8 MUSIC STANDS FOR THE ACTORS (4 OFFSTAGE LEFT, 4 OFFSTAGE RIGHT)
- * 6 MUSIC STAND LIGHTS FOR ACTORS (4 OFFSTAGE LEFT, 2 OFFSTAGE RIGHT)

NOTES

- * THE TRAPSET WILL NEED TO HAVE PLEXIGLASS AVAILABLE TO CHANNEL 34
- * WE NEED 15 FEET FROM THE EDGE OF THE STAGE TO THE CONDUCTOR'S PODIUM FOR ARTIST PROPS AND MICS.
- * THE TYPEWRITER WILL BE PROVIDED BY THE ARTIST.

** FOR THE COMPLETE STAY TUNED ORCHESTRA RIDER, PLEASE GO TO [HTTP://WWW.FIVEBYDESIGN.COM/STAYTUNED.HTML](http://www.fivebydesign.com/staytuned.html).

DESIGNED BY: DANIEL ELLIS

CYCLORAMA

LEG

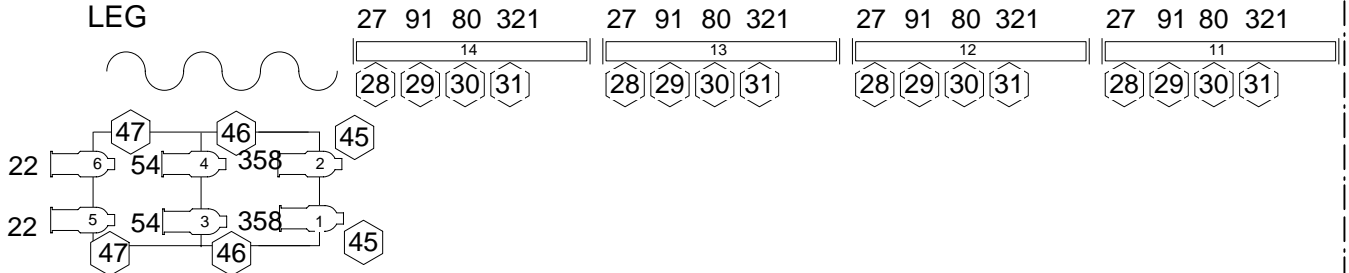

LADDER 3 SR and 4SR (optional)

LEG

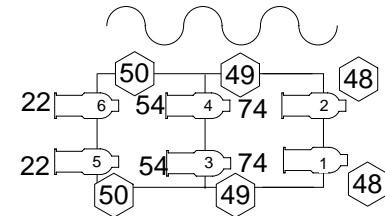

LADDER 1SR and 2SR (optional)

PLEASE NOTE: CONDUCTOR'S LIGHT

CHANNEL 32 IS TOP LIGHT FOR THE CONDUCTOR.
RELOCATE POSITION IF NECESSARY FOR COVERAGE.



LEG

ELECTRIC #2

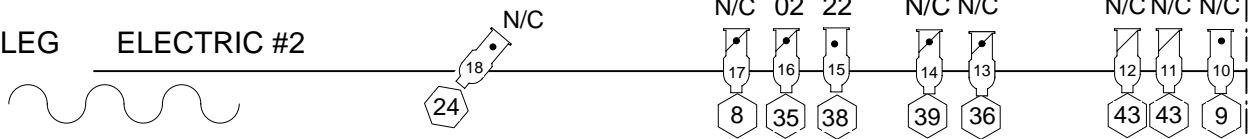

LEG

ELECTRIC #1

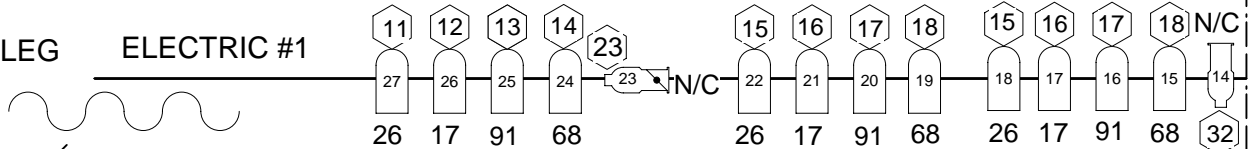

FOH

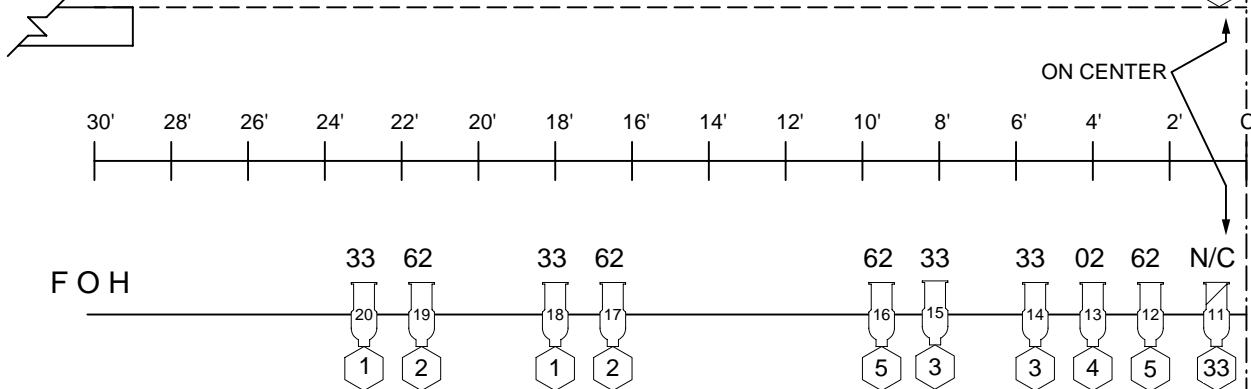

LEGEND

- 36° Source 4 or 6 x 9 (40°)
- 26° Source 4 or 6 x 12 (30°)
- 19° Source 4 or 6 x 16 (20°)
- PAR 64 (MEDIUM)
- STRIP AND/OR CYC LIGHTS (FLOOR MOUNTED AND/OR HUNG FROM GRID)
- PRACTICAL

INST. NUMBER
GOBO
COLOR
CHANNEL

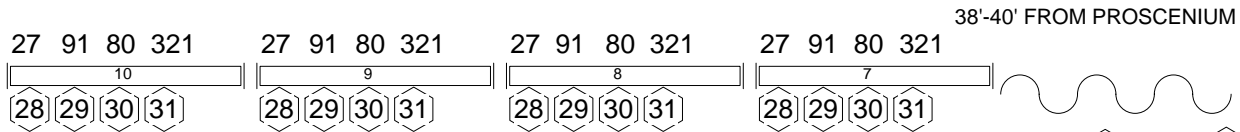

PLEASE NOTE: ORCHESTRA LIGHTING

I HAVE **NOT** INCLUDED INSTRUMENTS TO LIGHT THE ORCHESTRA. SINCE WE ARE NOT USING THE SHELL THAT WOULD PROVIDE LIGHTING, PLEASE HANG UNITS TO DO SO. A THREE COLOR WASH IS PERFERED (i.e. R27, R68, R17 IN CHANNELS 25, 26, 27 RESPECTIVELY).

PLEASE NOTE: SIDE LIGHTING (LADDERS)

SIDE LIGHTING IS NOT REQUIRED, BUT IS A GREAT ADDITION TO THE LOOK OF THE SHOW. I HAVE INCLUDED AN EXAMPLE OF SIDE LIGHTING IN THIS PLOT TO BE HUNG FOR THE ELECTRICS. (i.e. R358, R54, R22 IN CHANNELS 45, 46, 47 RESPECTIVELY). WE WOULD ALSO HANG SIMILAR SIDE LIGHTING ON ELECTRICS 1 AND 2 BUT WITH DIFFERENT COLOR (i.e. R74, R54, R22 IN CHANNELS 48, 49, 50 RESPECTIVELY).

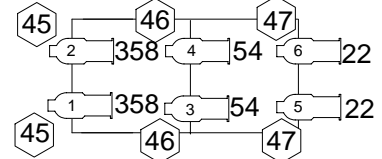

LADDERS 3SL and 4SL (optional)

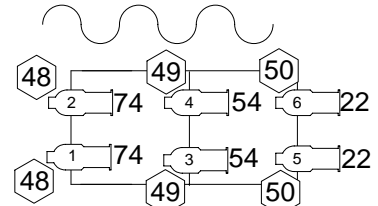

LADDER 1SL and 2SL (optional)



PRACTICAL FOR TV (ACT II)

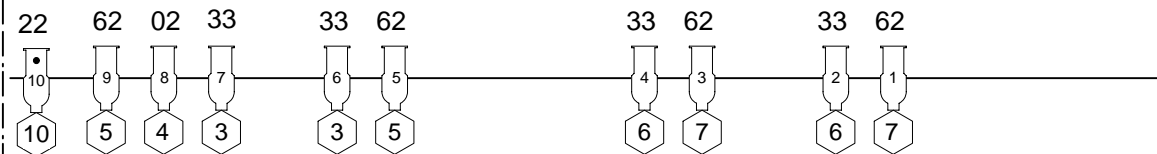
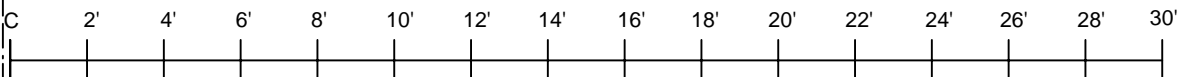
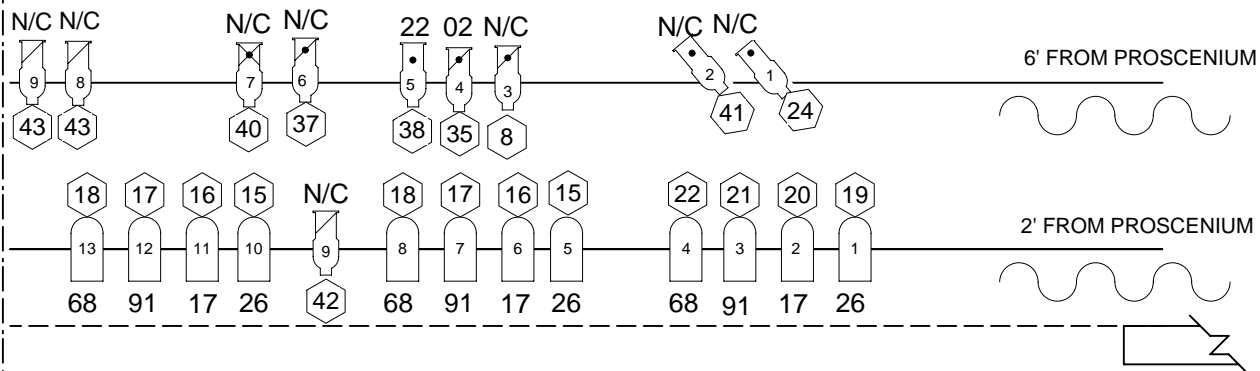

NOTES:

- 1-PLOT MUST BE HUNG AND GELLED PRIOR TO LOAD-IN. PLEASE INCLUDE DONUTS IN ANY INSTRUMENTS THAT ARE USING GOBOS.
- 2-FRONT OF HOUSE UNITS ARE BASED ON A MEDIUM THROW DISTANCE. IF YOUR FOH POSITION IS CLOSER OR FARTHER AWAY, PLEASE SUBSTITUTE APPROPRIATELY.
- 3-THE CYC SHOULD BE HUNG AS FAR UPSTAGE AS POSSIBLE (USUALLY ABOUT 38'-0" TO 40'-0" FROM THE PROSCENIUM).
- 4-ALL GEL IS ROSCO LUX. **SPOT COLOR IS ROSCO 02, 33,54, 60 AND 132 (IN FRAMES 1 THRU 5 RESPECTIVELY).**
- 5- I UNDERSTAND EACH VENUE MAY HAVE CERTAIN LIMITATIONS. ALTERNATIVES AND SUBSTITUTIONS SHOULD BE DISCUSSED PRIOR TO LOAD-IN.
- 6-ORCHESTRA STAND LIGHTS SHOULD BE DIMMABLE, PATCHED INTO THE LIGHT BOARD AS CHANNEL 34.
- 7-THERE ARE A NUMBER OF GOBO EFFECTS IN THIS PRODUCTION. PLEASE SEE THE LIGHTING REQUIRMENTS PAGE OF THE RIDER TO SEE WHICH GOBOS NEED TO BE PROVIDED BY THE PRESENTER.
- 8-IF YOUR HOUSE DOES NOT HAVE FOUR COLOR CYC LIGHTS PLEASE USE A THREE COLOR SUBSTITUTION (R27, R91, R80 IN CHANNELS 28, 29, 30 RESPECTIVELY).

**** FOR THE COMPLETE STAY TUNED ORCHESTRA RIDER, PLEASE GO TO [HTTP://WWW.FIVEBYDESIGN.COM/STAYTUNED.HTML](http://www.fivebydesign.com/staytuned.html).**



