

# 8-Piece Band Show Rider



On behalf of the cast and crew of Five By Design's *Stay Tuned*, we wish to thank you for contracting the company as part of your upcoming season. To ensure that the performance runs efficiently, we require your Production/Technical Manager to thoroughly read the enclosed contractual and technical information and sign below. This rider is an integral part of the contract. Please be sure to retain the original document for your records and fax or mail a signed copy to us at:

Five By Design  
1160 Vierling Drive, #353  
Shakopee, MN 55379-4313  
Fax # (952) 400-4229

We understand each venue may have certain limitations. Please feel free to contact us to discuss alternatives or substitutions if you should have any questions regarding the materials contained in this rider. We can be reached through our offices at (800) 449-7345.

Warmest regards,

Five By Design

\_\_\_\_\_  
**(Production/Technical Manager)**

\_\_\_\_\_  
**(Telephone Number)**

\_\_\_\_\_  
**(Date)**

**Five By Design personnel:**

Kurt Niska .....	Artistic Director/C.E.O.....	(612) 802-8171
Michael Swedberg .....	Executive Director.....	(612) 991-2308
Midge Swedberg .....	Office Manager .....	(800) 449-7345
Sheridan Zuther.....	Operations Manager .....	(612) 799-0245
Laurel Stinson.....	Technical Director.....	(612) 991-2193
Phil Henrickson.....	Sound Engineer .....	(920) 755-2328
Terrence Niska .....	Music Librarian & Marketing Director.....	(952) 496-2358
Lorie Carpenter-Niska .....	Tour Coordinator.....	(952) 496-2358

**Artist Representation:**

Alton Accola.....	<i>Symphony Pops</i> .....	(800) 449-7345
Catherine Scott.....	<i>Performing Arts Centers</i> .....	(612) 991-3528
Steve Pritchard.....	<i>Music City Artists</i> .....	(615) 383-4862

## ***Stay Tuned 8-Piece Band Rider***

These items are necessary to a successful production. Your assistance in providing this information and materials will greatly assist Five By Design to present the best possible performance.

Please review the enclosed pages and call us at (800) 449-7345 if you have questions or concerns.

### **Five By Design personnel:**

Kurt Niska .....	Artistic Director/C.E.O.....	(612) 802-8171
Michael Swedberg .....	Executive Director .....	(612) 991-2308
Midge Swedberg .....	Office Manager .....	(800) 449-7345
Sheridan Zuther.....	Operations Manager .....	(612) 799-0245
Laurel Stinson.....	Technical Director .....	(612) 991-2193
Phil Henrickson.....	Sound Engineer .....	(920) 755-2328
Terrence Niska .....	Music Librarian & Marketing Director.....	(952) 496-2358
Lorie Carpenter-Niska .....	Tour Coordinator.....	(952) 496-2358

### **IN ADVANCE:**

- 1) Professional lighting and sound system to meet specifications of the enclosed "Lighting" and "Sound" requirements. Experienced technicians should be available to assist with Load-In, Load-Out, and to answer any questions. Please read the attached "Lighting" and "Sound" pages for specific information.
- 2) Business and/or home phone numbers of presenter, venue's technical director and staff.
- 3) A map detailing the location of hotel, performing arts venue, appropriate routing, and phone numbers. Please be specific as to the location of loading dock and the stage door of your venue when providing directions.
- 4) A schematic of the performance venue stage (including an inventory of lighting and sound equipment).
- 5) Hotel or Motel (Residence Inn, Courtyard, Comfort Suites, or comparable) near venue with swimming pool, sauna, whirlpool, exercise facility and internet access. **NON-SMOKING ROOMS** are required, all at the same complex.
- 6) Allow broadcast and print media the opportunity to photograph and/or videotape segments of the rehearsal or performance with the orchestra. (No flash photography during performance.)
- 7) Regarding social functions or outreach activities, please inform company a minimum of 30 days in advance.
- 8) If contract states presenter is responsible for providing part or all of the band, please provide names and address of who is to receive the musical scores and parts. Please provide rehearsal availability and schedule as soon as possible to our Operations Manager.
- 9) Piano is to be provided by presenter. If contract states presenter is responsible for providing part or all of the band, an Acoustic Bass (with Pickup and Amplifier) and Drum Kit may need to be provided by presenter. Please see the "instrumentation list" for specific information.
- 10) Production specific marketing and promotional materials are available for the presenter at company's website: <http://www.fivebydesign.com/StayTuned.html>. Prior to going to print, contact our Operations Manager for program information, content and layout approval (i.e. personnel and program changes). If additional needs or questions arise, please contact our Marketing Director for assistance.
- 11) Contact Five By Design's Operations Manager to arrange a hot meal for sixteen (16) during load-in/prior to the show.

# *Stay Tuned 8-Piece Band Rider*

## **PRIOR TO LOAD-IN:**

- 1) Piano must be tuned prior to (but within 24 hours of) Load-In, following Rehearsal prior to performance, and before each subsequent performance. If venue has a second (rehearsal) piano, please make it accessible for warm up prior to show and during intermission.
- 2) The Stage Set-Up must be complete prior to Load-In. Lighting instruments should also be pre-hung and gelled before Load-In. See attached "Set-Up Diagram" and "Lighting" for specific requirements

## **AT LOAD-IN:**

- 1) Performance venue must be available for Load-In a minimum of eight (8) hours prior to rehearsal with the band. (In the event of an AM rehearsal, venue must be available for Load-In the afternoon prior.)  
Performance venue must also be available Two (2) hours prior to each performance.
  - Load-In and prep for show typically takes six (6) to seven (7) hours [not including meal breaks].
  - Load-Out typically takes two (2) to two and a half (2 1/2) hours.
- 2) Six (6) Stagehands for Load-In and Load-Out, and to assist with other incidental needs:
  - Load-In and Load-Out Crew Requirements: 1 Sound, 1 Light, 1 Wardrobe, 3 Hands.
  - Show Call Crew Requirements: 1 Sound, 1 Light, 1 Follow spot, 3 Stage Crew (2 stage left, 1 stage right).
- 3) The following are required no later than Load-In time:
  - Two (2) sturdy movable clothing racks (preferably high enough to accommodate floor length gowns).
  - Two (2) eight foot table (1 stage left and 1 stage right).
  - Music stands for band plus eight (8) extra for actors (4 offstage left, 4 offstage right).
  - Music stand lights for orchestra plus six (6) extra for actors (4 offstage left, 2 offstage right). Onstage lights will be on a dimmer. Company will provide a light for the piano that should be included in the circuit allocated to the stand lights. See attached "Lighting" rider.
  - 16 total chairs (7 chairs offstage right, 8 chairs offstage left, 1 chair for Typewriter).
  - One (1) adjustable piano bench.
  - Pipe and drape may be needed to create two (2) Quick change areas: one located Stage Left 16' x 20', and one Stage Right 16' x 12'. These locations will be determined during Load-In.
  - Three (3) gallons of **distilled** water for our clothing steamers. (**Not** drinking, spring or tap water).
  - Access to stage from house, i.e. steps (on at least the stage right side for rehearsals and performances).
  - Hot herbal tea (non caffeinated with honey and lemon) regular coffee, non carbonated bottled water (i.e. Evian), Coca-Cola and cups. Please have bottled water, herbal tea and coffee available at rehearsal(s) and performance(s) as well.
  - A fruit and veggie tray available for cast and crew following each performance(s).
  - Five (5) clean Dressing Rooms to accommodate 2 people each, through run of show.
  - Company travels with a 24' box truck (35' feet long, 13' high) and a 15 passenger van. Please arrange for level, secure parking. The truck is equipped with a battery cut-off switch.

# ***Stay Tuned 8-Piece Lighting Requirements***

Questions regarding lighting requirements contact:

Laurel Stinson, Technical Director ..... cell: **(612) 991-2193**

e-mail: **laurel.stinson@fivebydesign.com**

- Please mail or fax a schematic of your performance venue stage and lighting grid (including a lighting inventory) to the company's Operations Manager.

*Stay Tuned* requires a safe and well maintained lighting system. The inventory must be adequate to complete the hanging of the enclosed plot prior to Load-In. Please have a safe lift or ladder available for focus. **If you anticipate the need to rent any equipment for your venue, please contact our Technical Director prior to doing so, to make certain it is necessary. Substitutions may be suggested.**

## **Console**

The lighting console must be either a computer memory console or a two scene preset board with a minimum of 48 channels (ETC or STRAND family is preferred).

## **Follow spot**

We require one (1) follow spot adequate to the venue. A Xenon Super Trouper is preferred for medium to large venues. Spot Color is Rosco 02, 33, 54, 60, 119 or 132 in frames 1 through 5 respectively. LEE or GAM substitutions are acceptable.

## **Crew Requirements**

We require one technician familiar with your lighting system to be present at Load-In and during the run of the show, and one follow spot operator for run of the show. Our Technical Director will operate the board for the run of the show. If this presents a problem, please contact our technical personnel at least thirty (30) days in advance of the performance. Six (6) Stagehands for Load-In and Load-Out, and to assist with other incidental needs:

- Load-In and Load-Out Crew Requirements: 1 Sound, 1 Light, 1 Wardrobe, 3 Hands.
- Show Call Crew Requirements: 1 Sound, 1 Light, 1 Follow spot, 3 Stage Crew.

## **Big Band Requirements**

The Big Band Set-Up (see diagram attached) must be completed prior to the scheduled Load-In. The appropriate background for the production is a full-stage white **cyclorama** behind the band (hung 35'- 40' upstage of the proscenium). **Music stand lights are required for conductor and musicians.** (These stands are included in the count requested on page 3 in the "At Load-In" section.) **Stand Lights for the band will be on a dimmer, patched into Channel 34.** Please make a dimmer available. Refer to the Set-Up Diagram for additional requirements. Five By Designer will provide a light for the piano that should be included in the circuit allocated to the stand lights.

## **Gobo Requirements**

Presenter will provide the gobos listed below to fit their current lighting inventory. Substitutions may be discussed prior to Load-In. PLEASE NOTE: Five by Design will provide some additional gobos for the light plot **not** mentioned below.

### **ROSCO PATTERNS:**

- Two (2) - Pattern #77770 – Music (Channel 8 on light plot).
- One (1) - Pattern #77302 – Skyline 1 (Channel 35).
- One (1) - Pattern #77306 – Skyline 2 (Channel 35).
- One (1) - Pattern #79001 – Night Sky (Channel 40).
- Two (2) - Pattern #79111 – Jungle Vignette (Channel 38).
- One (1) - Pattern #77750 – Arcadia (Channel 41).

### **GAM PATTERNS:**

- One (1) – Pattern #517 – Twisting Branches (Channel 23).
- One (1) – Pattern #635 – Construction A (Channel 24).
- One (1) – Pattern #636 – Construction B (Channel 24).

## ***Stay Tuned 8-Piece Band Lighting Requirements (cont.)***

### **Important Information regarding the Light Plot**

- Trim heights in the plot are approximately 23 feet.
- All instruments should be at least 750 watts and should be consistent wattage for equal throw distances.
- If substitutions of either inventory or color are anticipated, please contact our technical/lighting director.
- The light plot is based on a sixty (60) foot proscenium. If your performance space is different, please expand or condense the spacing on the electrics as needed.
- Please refer to light plot attached for additional notes.
- Five By Design travels with a number of additional gobo patterns for the light plot that are not included in the "Gobo Requirements" on page 4. The venue will need to provide Size "B" pattern holders. Donuts may be required for all instruments using gobo pattern in order to ensure crisp patterns and breakups for the production.

**PLEASE NOTE:** In order to ensure a quick and proper load-in of the show, we ask that all lights be gelled and hung prior to load-in. If this can not be accommodated, please contact the Technical Director immediately.

# ***Stay Tuned 8-Piece Band Sound Requirements***

Questions regarding sound requirements contact:

**Phil Henrickson**, Sound Engineer: (920) 755-2328 .....fax: (920) 755-4442  
e-mail: philhenrickson@yahoo.com

- Company travels with a system adequate for a 1000 seat auditorium with no balcony. Please advise as to size of venue and type of in-house system available as Company may need to patch in to the House PA for additional coverage. **If you anticipate the need to rent any equipment for your venue, please contact our Sound Engineer prior to doing so, to make certain it is necessary.**
- Sound Engineer will use his own console for the purpose of mixing the live performance. Please provide a five (5) foot by eight (8) foot house-mix position for company's sound gear. Rear of house on the main floor is preferred.
- If the cable path from the stage to the House Mix position is greater than one hundred and fifty (150) feet, please provide one (1) Snake, with 24 in - 5 out minimum.
- Three (3) separate twenty (20) amp circuits exclusively for sound gear. One located at House Mix position, and one located off stage right and one for the Bass Player's amplifier onstage (see Set-Up Diagram).
- Please provide a Plexiglas surround for the drum kit (three of four sides is fine).
- Six (6) microphone stands. (three (3) boom stands and three (3) straight stands)
- Company travels with Four (4) monitors for the band. Please provide Two (2) 12" or 15" monitors for the company to use as needed.

## **Crew Requirements**

We require one technician familiar with your sound system to be present at Load-In, and during the run of the show. Six (6) Stagehands for Load-In and Load-Out, and to assist with other incidental needs:

- Load-In and Load-Out Crew Requirements: 1 Sound, 1 Light, 1 Wardrobe, 3 Hands.
- Show Call Crew Requirements: 1 Sound, 1 Light, 1 Follow spot, 3 Stage Crew.

## **Communication**

We require two-way headset communication at the following locations:

- lighting console
- follow spot
- stage left
- stage right
- sound mix

**PLEASE CALL 3 - 4 weeks prior** to Load In to clarify, verify, and address any concerns.

# ***Stay Tuned 8-Piece Band Stage Requirements***

Questions regarding stage requirements contact:

**Laurel Stinson**, Technical Director: ..... cell: **(612) 991-2193**

e-mail: laurel.stinson@fivebydesign.com

- The Big Band Set-Up (see diagram) must be completed prior to the scheduled Load-In
- The appropriate background for the production is a full stage white **Cyclorama** behind the band.
- We require a minimum of Seventeen (17) feet down stage of the piano for performance space. Please contact our Technical Director if this cannot be accommodated.
- We require two backstage wing space for quick changes: one offstage left (approximately 16' x 20') to accommodate two (2) clothes racks, one gondola, an 8'-0" table and eight (8) chairs and one area offstage right (approximately 16' x 12') to accommodate one gondola and seven (7) chairs.
- Theatre borders and legs will be used for masking. If this is not sufficient to properly mask quick change areas from audience view, pipe and drape may need to be provided. Quick change areas will be determined at Load-In.

## **Brief explanation of our Props:**

- All scenery elements on the Set-Up Diagram are pieces that we bring with us (including two (2) rolling set pieces, two (2) doors, the table for the typewriter, the table for the props for the commercial medley and the five (5) Microphones downstage center).
- A few scenery elements will roll on from stage right and stage left (two freestanding doors, two rolling sled units). These elements are designed to roll through a standard door frame. If there is no way that these items can physically go on and offstage, they will have to live onstage.

## **Items that the Presenter needs to provide:**

- Four (4) skirted risers for the Orchestra i.e. Wenger standard 4'-0" by 8'-0" and 4'-0" by 4'-0" risers at incremental heights 16" (or optional 8") and 24". **The back of both lower and upper levels must have a kick plate or chair rail attached.** The Big Band Set-Up (see diagram) must be completed prior to the scheduled Load-In.
- The appropriate background for the production is a full stage white **Cyclorama** behind the band (hung 35'- 40' upstage of the proscenium).
- **Music stands and stand lights** are required for the musicians. (These stands are included in the count requested on page 3 in the "At Load-in" section.) **The stand lights will be placed on a dimmer, patched into Channel 34.** Refer to the Set-Up Diagram for additional requirements. (Five By Design will provide a light for the piano that should be included in the circuit allocated to the stand lights).
- One (1) Concert Grand Piano. Piano must be tuned prior to (but within 24 hours of Load In, following Rehearsal prior to performance and before each subsequent performance.
- Two (2) 8 ft. table (1 offstage left and 1 offstage right).
- 8 music stands for actors (4 offstage right, 4 offstage left).
- 16 total chairs (7 chairs offstage right, 8 chairs offstage left, 1 chair for Typewriter).
- 1 adjustable piano bench.



1160 Vierling Drive, #353  
Shakopee, MN 55379-4313  
(952) 496-2358  
e-mail: [terrence.niska@fivebydesign.com](mailto:terrence.niska@fivebydesign.com)  
Terrence Niska, Librarian

## **Instrumentation List\* for *Stay Tuned* with 8-Piece Big Band**

- ◇ Lead Alto – (double flute, piccolo)
- ◇ Lead Tenor – (double bari sax, clarinet)
- ◇ Trumpet 1, 2 – (double flugelhorn) (all mutes)
- ◇ Trombone 1 with F Attachment (cup, harmon, straight and plunger mutes)
- ◇ Grand Piano
- ◇ Contrabass (1 only) — A Jazz upright with pickup and amplifier, bow  
3/4-7/8 Size Bass  
Fully Carved instrument with bow (German, French, Italian)  
Thomastik Spirocores strings  
Pickup attached, preferably "The Realist"  
Bass Amp Recommendations : Yamaha, Mesa Boogie
- ◇ Drum Set:  
Kick Drum, Snare Drum, Hi Tom, Medium Tom, Low (Floor) Tom, Hi-Hat, 2 Ride  
Cymbals, Crash Cymbal, Woodblock, Castanets, Sticks, Brushes, Soft Mallets for  
Cymbals, Cowbell, Throne, Area Rug

# STAY TUNED (8-PIECE) SET-UP DIAGRAM

35'-40" FROM PROSCENIUM

CYCLORAMA

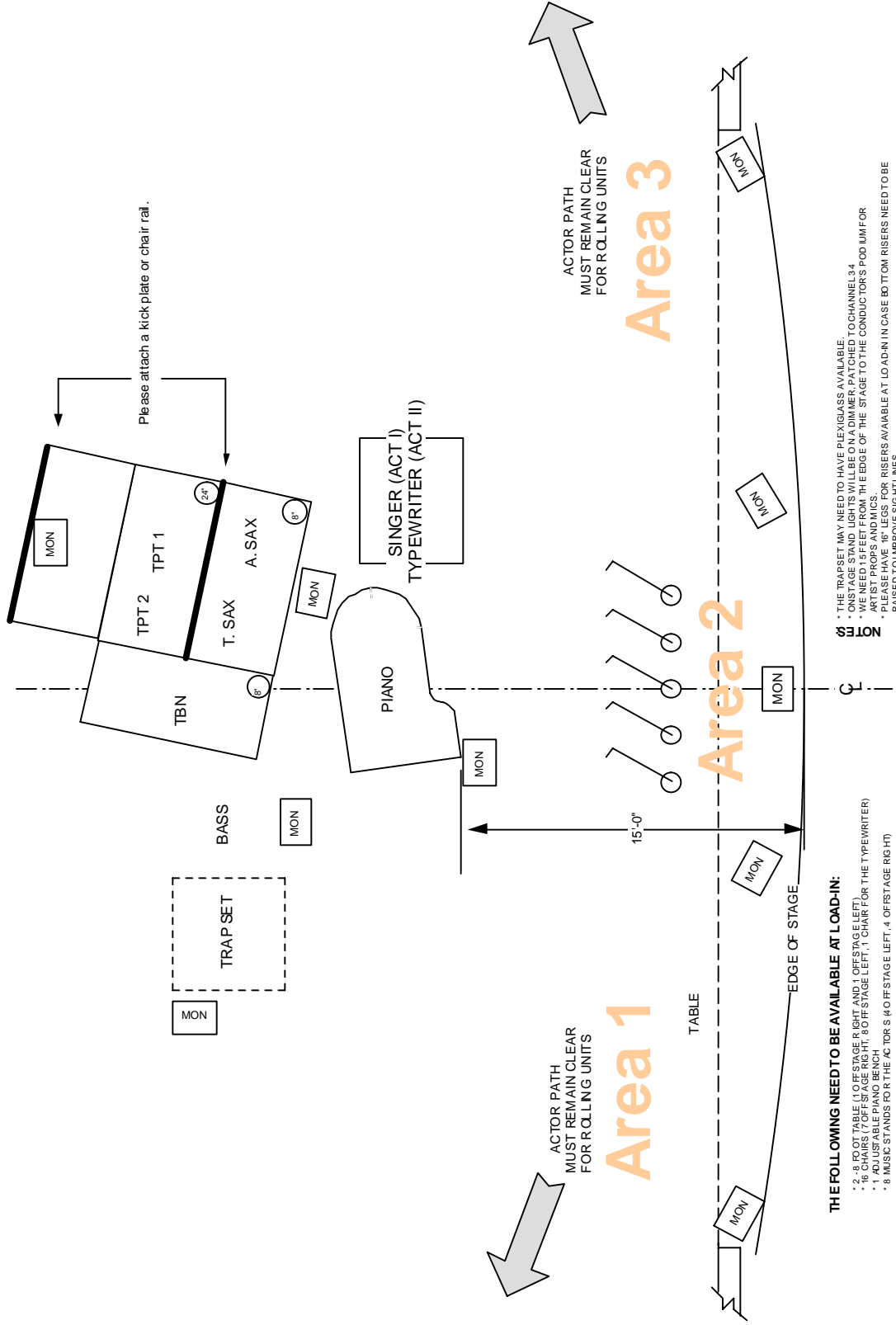

- NOTES**
- \* THE TRAP SET MAY NEED TO HAVE PLEXIGLASS AVAILABLE.
  - \* ON STAGE STAND LIGHTS WILL BE ON A DIMMER PATCHED TO CHANNEL 3.4
  - \* WE WILL BE USING THE EDGE OF THE STAGE TO THE CONDUCTOR'S PODIUM FOR ALL SET PROPS AND MUSIC.
  - \* PLEASE HAVE 16" LEGS FOR RISERS AVAILABLE AT LOAD-IN IN CASE BOTTOM RISERS NEED TO BE RAISED TO IMPROVE SIGHTLINES.
  - \*\*FOR THE COMPLETE STAY TUNED ORCH STRA ORDER, PLEASE GO TO [HTTP://WWW.FIVEBYDESIGN.COM/STAYTUNED.HTML](http://www.fivebydesign.com/staytuned.html)

- THE FOLLOWING NEED TO BE AVAILABLE AT LOAD-IN:**
- \* 2-8 FOOT TABLE (1 OFF STAGE RIGHT AND 1 OFF STAGE LEFT)
  - \* 16 CHAIRS (7 OFF STAGE RIGHT, 8 OFF STAGE LEFT, 1 CHAIR FOR THE TYPEWRITER)
  - \* 16 MUSIC STANDS FOR THE ACTORS (4 OFF STAGE LEFT, 4 OFF STAGE RIGHT)
  - \* 8 MUSIC STANDS FOR THE ACTORS (4 OFF STAGE LEFT, 2 OFF STAGE RIGHT)
  - \* 6 MUSIC STAND LIGHTS FOR ACTORS (4 OFF STAGE LEFT, 2 OFF STAGE RIGHT)

CYCLORAMA

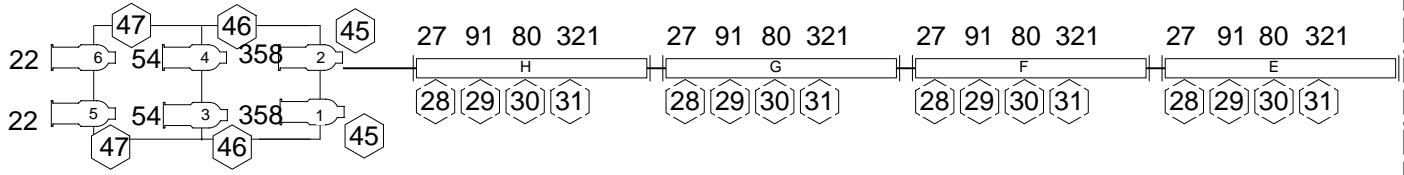

LADDER 3 SR and 4SR (optional)



ELECTRIC #3

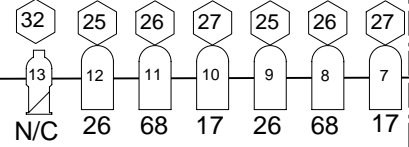

PLEASE NOTE: CONDUCTOR'S LIGHT

CHANNEL 32 IS TOP LIGHT FOR THE CONDUCTOR.  
RELOCATE POSITION IF NECESSARY FOR COVERAGE.



MUSIC STAND LIGHTS

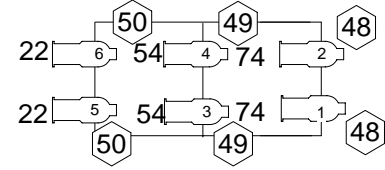

LADDER 1SR and 2SR (optional)



ELECTRIC #2

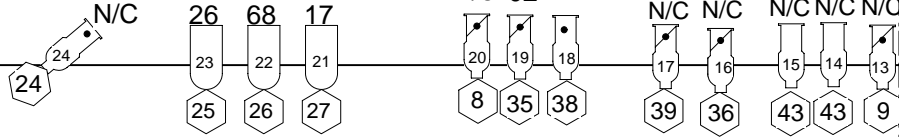

ELECTRIC #1

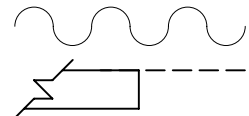
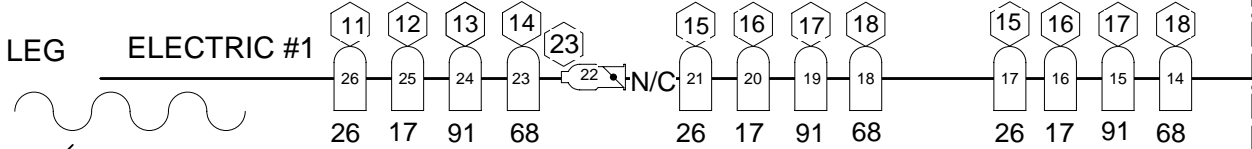

ON CENTER

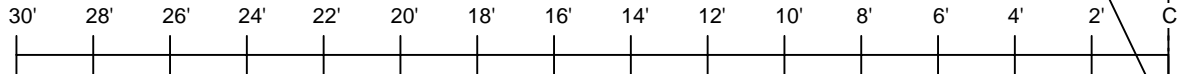

FOH

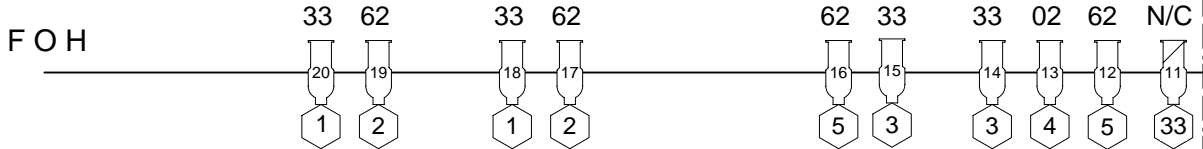

**LEGEND**

- 36° Source 4 or 6 x 9 (40°)
- 26° Source 4 or 6 x 12 (30°)
- 19° Source 4 or 6 x 16 (20°)
- PAR 64 (MEDIUM)
- STRIP AND/OR CYC LIGHTS (FLOOR MOUNTED AND/OR HUNG FROM GRID)
- PRACTICAL

INST. NUMBER  
GOBO  
COLOR  
CHANNEL

STAY TUNED LIGHT PLOT (BIG BAND)

DESIGNED BY: DANIEL ELLIS Updated 5/15/07

38'-40' FROM PROSCENIUM

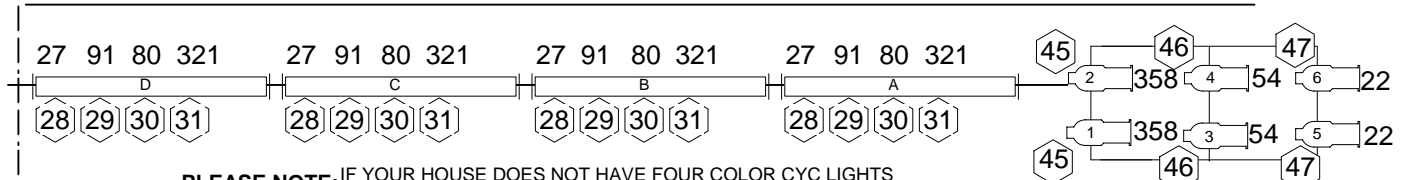

**PLEASE NOTE:** IF YOUR HOUSE DOES NOT HAVE FOUR COLOR CYC LIGHTS PLEASE USE A THREE COLOR SUBSTITUTION (R27, R91, R80... IN CHANNELS 28, 29, 30 RESPECTIVELY). CYC LIGHTS MAY BE HUNG ONLY FROM THE GRID IF VENUE DOESN'T HAVE THE INVENTORY FOR FLOOR MOUNTED CYCS AS WELL.

LADDERS 3SL and 4SL (optional)

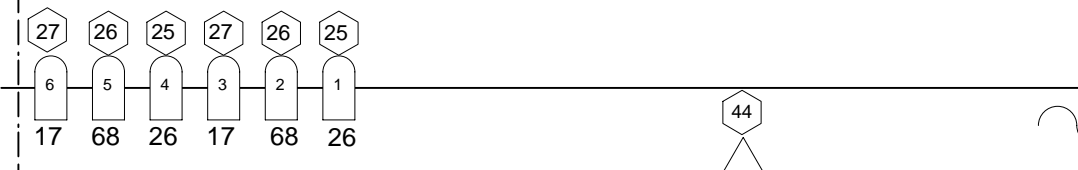

PRACTICAL FOR TV (ACT II)

**PLEASE NOTE: SIDE LIGHTING (LADDERS)**

SIDE LIGHTING IS NOT REQUIRED, BUT IS A GREAT ADDITION TO THE LOOK OF THE SHOW. I HAVE INCLUDED AN EXAMPLE OF SIDE LIGHTING IN THIS PLOT TO BE HUNG FOR THE ELECTRICS. (i.e. R358, R54, R22 IN CHANNELS 45, 46, 47 RESPECTIVELY) and (i.e. R74, R54, R22 IN CHANNELS 48, 49, 50 RESPECTIVELY).

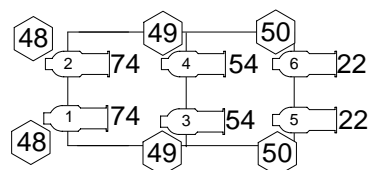

LADDER 1SL and 2SL (optional)

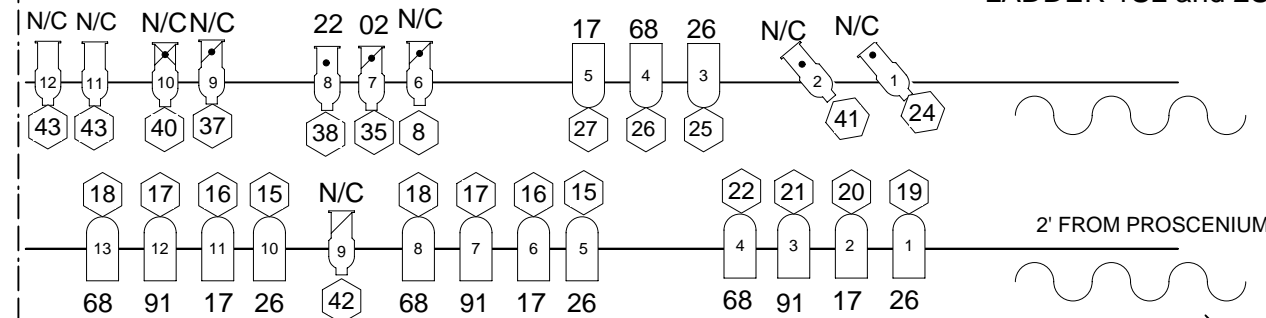

2' FROM PROSCENIUM

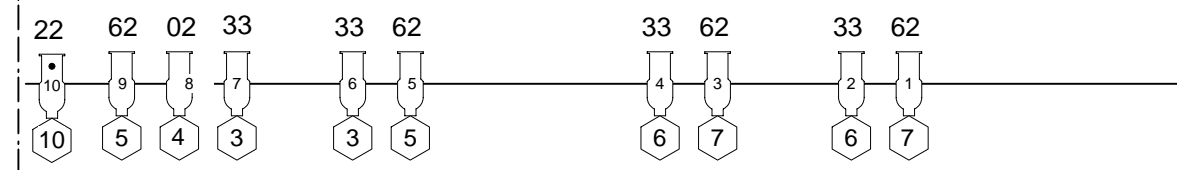
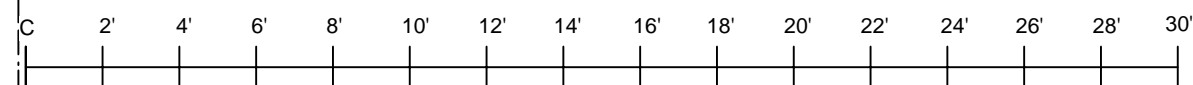

**NOTES:**

1-PLOT MUST BE HUNG, GELLED, AND PATCHED PRIOR TO LOAD IN. PLEASE INCLUDE DONUTS IN ANY INSTRUMENTS THAT ARE USING GOBOS

2-FRONT OF HOUSE UNITS ARE BASED ON A MEDIUM THROW DISTANCE. IF YOUR FOH POSITION IS CLOSER OR FARTHER AWAY, PLEASE SUBSTITUTE APPROPRIATELY.

3-THE CYC SHOULD BE HUNG AS FAR UPSTAGE AS POSSIBLE (USUALLY ABOUT 38'-0" TO 40'-0" FROM THE PROSCENIUM).

4-ALL GEL IS ROSCO LUX. SPOT COLOR IS ROSCO 02, 33, 54, 60 AND 132.

5-EACH VENUE MAY HAVE CERTAIN LIMITATIONS. ALTERNATIVES SHOULD BE DISCUSSED PRIOR TO LOAD IN. PLEASE CONTACT TECHNICAL DIRECTOR, DANIEL ELLIS AT (612) 991-2193, IF CHANGES NEED TO BE MADE.

6-BIG BAND STAND LIGHTS SHOULD BE DIMMABLE (THEY WILL BE PATCHED INTO CHANNEL 34 AND CONTROLLED AT THE LIGHTBOARD.)

7-SUBSTITUTIONS MAY BE MADE FOR INSTRUMENTS BASED ON VENUES INVENTORY (i.e. FERNELLS FOR PARS) PLEASE DISCUSS SUBSTITUTIONS PRIOR TO LOAD-IN.



STAY TUNED (8-PIECE) SOUND AND PATCH SHEET

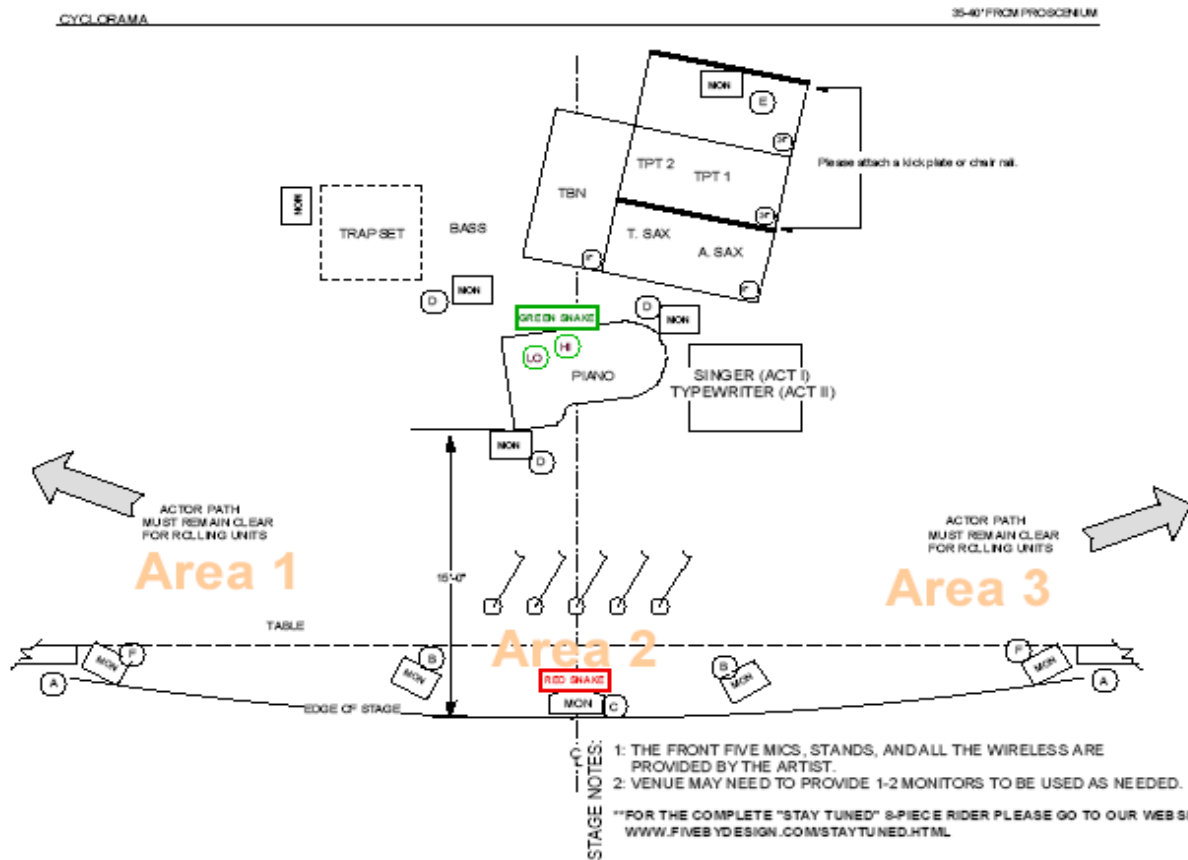

STAY TUNED (8 PIECE) SOUND PATCH SHEET

Allen_Heath	Mic	Main_Snake	Red_Sub_Snake	Green_Sub_Snake
1	Vocal 1 (stand)	1	1 - Act 2	1 - Act 1
2	Vocal 2 (stand)	2	2 - Act 1 & 2	
3	Vocal 3 (stand)	3	3 - Act 1 & 2	
4	Vocal 4 (stand)	4	4 - Act 1 & 2	
5	Vocal 5 (stand)	5	5 - Act 2	5 - Act 1
6	Mike Wireless	6		
7	Sheridan Wireless	7		
8	Kurt Wireless	8		
9	Lorie Wireless	9		
10	Terry Wireless	10		
11	"Typewriter"	11		√Act 1 & 2 √ 2 - Typewriter
12	Guitar (Lorie)	12		
13	Piano - Low	13		3 - Piano Low
14	Piano - High	14		4 - Piano High
15	Bass	15		6 - Bass
16	MD FX Tracks	16		
17	Sax 1	17		7 - Sax 1
18	Sax 2	18		8 - Sax 2
19	Flute	19		9 - Flute
20	Drum Kit	20		10 - Drum Kit
21	Trombone	21		11 - Trombone
22	Trumpet 1	22		12 - Trumpet 1
23	Trumpet 2	23		13 - Trumpet 2
24	OPEN	24		
25	OPEN	25		
26	(drums monitor send)	26		

-Monitors-	-Send_Lines-
Delta Max (House)	A
Front Floor Sides (2)	B
Front Center Floor	C
Piano / Bass	D
Back Horns	E
Front L/R Sidefills	F
Drums	Line 2.6

\*\*FOR THE COMPLETE STAY TUNED ORCHESTRA RIDER, PLEASE GO TO [HTTP://WWW.FIVEBYDESIGN.COM/STAYTUNED.HTML](http://www.fivebydesign.com/staytuned.html)